

MANUFACTURER'S PREMIUM COVER™ LIFETIME LIMITED WARRANTY

Agri-Cover, Inc. extends the following lifetime limited warranty to the original retail purchaser of any ACCESS® Roll-Up Covers purchased after July 1, 2002:

Agri-Cover, Inc. warrants its ACCESS® Roll-Up Cover to be free from defects in material and workmanship for as long as the original purchaser owns the truck on which the cover was originally installed and as long as the cover remains continuously installed on said truck.

Agri-Cover's sole obligation under this limited warranty is limited to the repair or replacement, at its option, of defective parts only. No labor or service allowance is given or implied. IN NO EVENT SHALL AGRI-COVER, INC. BE LIABLE FOR INCIDENTAL, CONSEQUENTIAL, OR SPECIAL DAMAGES. AGRI-COVER, INC. EXPRESSLY DISCLAIMS ANY AND ALL IMPLIED WARRANTIES OF MERCHANTABILITY, AND THERE ARE NO WARRANTIES WHICH EXTEND BEYOND THE LIMITED WARRANTY DESCRIPTION CONTAINED HEREIN.

For warranty performance call our Customer Service Department at 701-251-1427 to determine if only a replacement part is needed or if the cover needs to be returned for inspection and repair. **Warranty registration must be on file and/or proof of original purchase (detailed and dated receipt) required for warranty to be effective. Goods to be returned must have a pre-authorized RA # (Returned Authorization Number) – obtained by calling the number above. Mark the number on the package and ship it freight prepaid to address below. Agri-Cover will pay freight to return goods to sender.**

This limited warranty does not cover any damage due to accident, abuse, misuse, alteration, neglect, improper installation, or ordinary wear and tear.

This limited warranty gives you specific legal rights and you may have other rights, which vary, from state to state.



Agri-Cover, Inc.
Customer Service Dept.
3000 Hwy. 281 SE
PO Box 508
Jamestown, ND 58402
Phone: 701-251-1427

ACCESS is a registered United States trademark of AGRI-COVER, INC.
U.S. Patent Nos. 5,076,338; 5,174,353; 6,543,835; 6,672,644; 6,851,738; 7,048,227;
7,008,000; 7,104,586; 7,066,524 and other patents pending.

Phone 701-251-1427 8 am - 5 pm Central Standard Time
Monday thru Friday except Holidays



BY



INSTALLATION INSTRUCTIONS AND OWNER'S MANUAL

Thank you for purchasing an ACCESS roll-up cover. ACI has manufactured this roll-up cover with pride using superior quality materials and craftsmanship. With proper care, your cover will provide years of service and enjoyment.

NOTICE TO INSTALLER: It is recommended you take the time to read these instructions before installing this cover even if already familiar with the product. Often improvements are made without prior notice. Always handle cover and components with care to avoid damage. If you find a part missing or defective, or if you are having trouble installing this product, please have serial number ready (found on decal under rear bar by tailgate) and call the customer service number on the back page. **When done, these instructions and warranty information must be given to the consumer.**

NOTICE TO CONSUMER: Before using this product, read the operating instructions, maintenance and safety sections of this owners manual and save for future reference.

FOR YOUR RECORDS:

DATE PURCHASED _____

WHERE PURCHASED _____

SERIAL NUMBER _____
(Located on decal under rear bar by tailgate)

WARRANTY REGISTRATION

Promptly confirm your warranty by registering on-line at www.agricover.com.

INSTALLATION INSTRUCTIONS: (Note: For additional installation assistance go online to accesscover.com, instruction manual and click on installation video.)



PREPARATION: Unpack cover components. Clean truck box if dirty.

- | | | |
|-----------------------|---|--------------------------------|
| 1 driver side rail | 8 clamps | 1 pre-rolled up cover assembly |
| 1 passenger side rail | 1 left and 1 right tension adjuster with washer, nuts and bolts | |
| 1 Element Seal Kit | | |

TOOLS NEEDED:

- | | | |
|---|---------------------------|--------------------|
| 2 - 9/16" wrenches | | |
| 1 - Spring clamp (to hold rails in place while clamping) optional | | |
| 1 - Scissor | 1 - Tape measure or ruler | Protective eyewear |

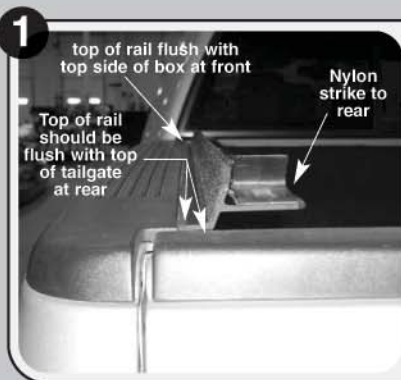

Align weatherstrip edge of side rail against inside lip of box and push it forward until it stops against front of box (nylon strike goes to rear). At front, rail should be flush with side top of box. At rear, rail should be flush with top of tailgate. See photo at left.

Hold rail in place with spring clamp and close tailgate to check height. Then place 1st clamp as close to front as possible and use a 9/16" wrench to tighten. See photo at right. **Note: Some installs require drilling/bolting. See extra insert instructions included with kit for rail attachment. Then proceed to #3 of these instructions.**

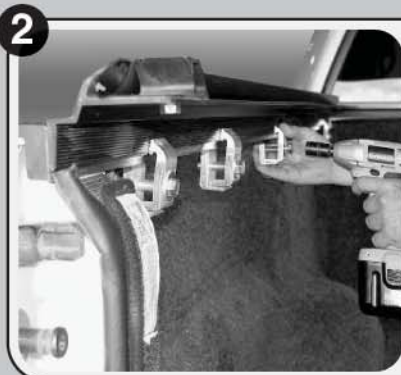

Next install a 2nd clamp at midway point of box and rail. Now check rail for level. See photo at left and illustration at right. If rail tilts up, move clamps down and tighten. If rail tilts down, move clamps up and tighten. Install third clamp as close to tailgate as possible - and last clamp centered between middle and tailgate. See photo at left. Make sure all clamps are placed in best up or down position for a level rail. Then recheck clamps to ensure adequate tightness.

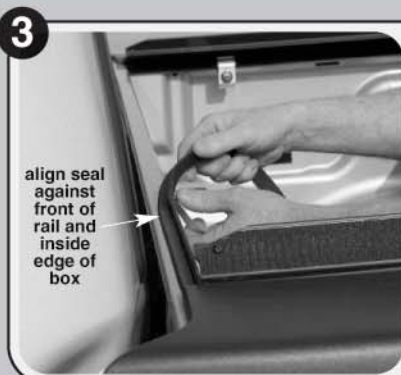
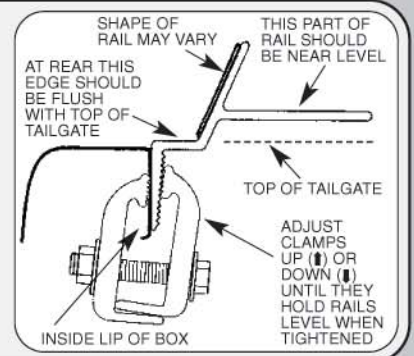

At front of box header, clean top surface with alcohol pad (if needed wash first). Peel paper back, align and adhere Element Seal™ at one corner across box to opposite corner and cut to length. See photo at left and illustration at right.

Note: For additional protection - locate and seal miscellaneous factory holes, crevices, stake pockets, etc. that may be on box (sealant not included).

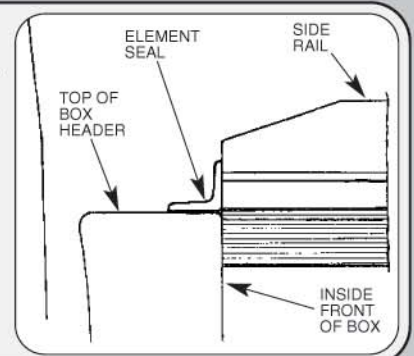

4

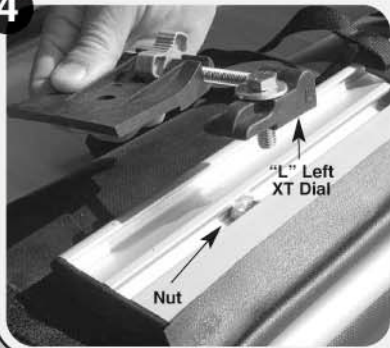

The cover comes pre-rolled to its normal open position for ease of installation. Set pre-rolled cover on tailgate with front bar facing up as shown. Align XT Dial Tension Adjuster (marked L) on driver side of cover - positioned as shown in photo at left.

Turn 1-1/4" bolt with flat washer onto nut in bar. Leave loose for now. *See photo at right.* Repeat for XT Dial (R) on passenger side of cover, and leave that bolt loose also.



5



Set rolled up cover on rails at front of box (behind cab) with bar facing up. Roll cover bar onto front of rails and fold/tuck vinyl flap under. Now bar will face down. Let straps hang to inside of box. *See photo at left.*

Push cover bar forward until it sets flat on front of side rails and overhangs them. Slide left tension adjuster over until it engages under side rail. Push bar back and forth to line up holes - do not turn dial wheel. Insert bolt from top and flat washer and nut from bottom. *See photo at right.*

Note: These holes are designed for a snug fit - you may need to turn the bolt through rail and adjuster with wrench. The bolt will thread through without harming any pieces.



Hold bolt at top and tighten nut under side rail. Repeat procedure for right hand tension adjuster. *See photo at left.*

Center the front bar between the two side rails. *See photo at right.*

Then tighten bolt (left loose earlier) under front bar on each tension adjuster. *See photo at far right.*



6



Unroll cover and place rear bar into strikes on side rails and press down on bar to close (20-30 pounds pressure).

Note: See operating instructions on page 4.

Close tailgate slowly - top of tailgate should fit snug under cover bar. If it is too tight - raise rails by loosening rear clamps adjust rail up and tighten clamps. If too loose adjust rails lower.



Check cover tension by releasing autolatch and open and close rear bar several times. It should snap down when closing. Cover fabric should sound drumlike when tapped on. If adjustment is needed, roll cover open and **turn XT dial counter-clockwise to tighten, clockwise to loosen. Always turn dials in equal amounts.** *See photo at left.*

When done, seal both sides of cover with hook and loop system. *See photo at right.*

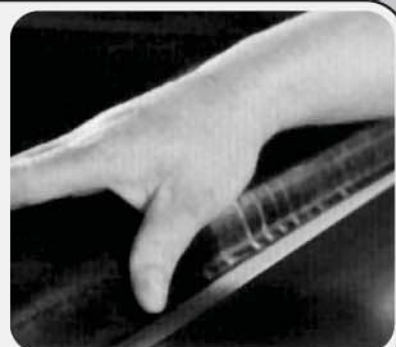

OPERATING INSTRUCTIONS: (Note: view opening and closing demonstration video on access.com.)

TO CLOSE



Release retainer straps at front and using both hands roll cover out to rear of box.



Position roll-up bar against strikes. Push down on bar until autolatch locks in place.



Now along side of box, seal cover edges with hook and loop sealing system the full length of cover on both sides. Pull with one hand - seal with other hand.

OPTIONAL USE



Manual Slide Lock (use is optional) - under cover bar on passenger side - push slide lock to engage.

TO OPEN



Open tailgate on driver side pull autolatch and lift up on rear of roll bar.



Using both hands, roll cover toward front of box (not against cab).



Securely fasten retainer straps to store the cover.

OPTIONAL USE



Under cover bar on passenger side - if slide lock is locked pull to disengage.

SAFETY WARNING: ALWAYS FINISH SECURING THE COVER. USE CAUTION WHEN OPERATING COVER IN WINDY CONDITIONS.

INSPECTION AND MAINTENANCE

- Inspection and much of the maintenance can be done by the operator. It may be necessary to review the installation and operating instructions.
- Periodically inspect the cover assembly. Check for loose bolts and parts and the condition of all parts. Test the operation to ensure that the parts are functioning properly and that the cover is in top operational condition.
- If autolatch has been damaged replace with new one. **NOTE:** Inspection and/or maintenance should also be performed anytime a malfunction is observed or suspected. If you need assistance inspecting and/or servicing your cover, or if you want to order a replacement part, call the customer service number on the back page. Always use original equipment replacement parts for your cover.
- Vinyl cover can be treated with water base vinyl protectants. Avoid silicon base products.
- When cleaning, for best results use mild liquid soap and water. Never clean cover with petroleum or citrus base products.

SAFETY INFORMATION

- Do not cover cargo that is higher than the cover.
- Do not place object(s) on or against the cover or its framework at any time.
- Always secure cargo so cargo can not shift and damage the cover or its parts.
- Do not use the covers' framework to tie down cargo.
- Never stand, sit or ride on the cover or allow others to do so.
- Do not leave valuables in an unattended vehicle as the cover does not prevent theft of contents in the truck box.
- The cover does not eliminate moisture and dust from entering the truck box. Special wrapping or packaging of the contents may be necessary.
- Due to poor ventilation, if you allow a pet animal in the box, leave cover open. Do not allow people or animals to occupy box with the cover closed.
- When towing vehicle backwards, cover must be rolled fully open and secured with safety straps or fully closed and secured with manual slide lock.

TROUBLESHOOTING

PROBLEM	SOLUTION
Cover too loose...	...Turn both tension adjusters counter clockwise to move front bar forward. (Refer to #6, see arrows next to adjuster)
Cover too tight...	...Turn both tension adjusters clockwise to move front bar rearward. (Refer to #6, see arrows next to adjuster)
Gap between roll-up bar and tailgate...	...Rails set too high. (Refer to #6)
Cover is too wide...	...Check rails. Rails in - too wide - push all clamps to top of rail. Falls out - too narrow - pull all clamps down on rail. (Refer to #2)
Lopsided cover too much on one side...	...Check front bar. It must be centered side to side. (Refer to #5)
Top of tailgate hits rear bar when attempting to close...	...Raise side rails at rear of box until tailgate closes without pushing rear bar up. (Refer to #6)
Auto latch doesn't engage...	...Check side rails for height and level. Inspect latch for jammed or broken parts. (Refer to #2)
Manual slide lock (passenger side) too loose or too tight...	...Use 1/8" allen wrench and adjust set screw tighter or looser as desired. Lock performs best with some friction.

PARTS DIAGRAM

